

**JIMCO**<sup>®</sup>

UV-C & OZONE  
Technology



**JIMCO**<sup>®</sup>  
UV-C  
www.jimco.dk

ENVIRONMENTALLY FRIENDLY

**DISINFECTION  
FLO-D<sup>®</sup> TECHNOLOGY**



JIMCO.DK

# DISINFECTION

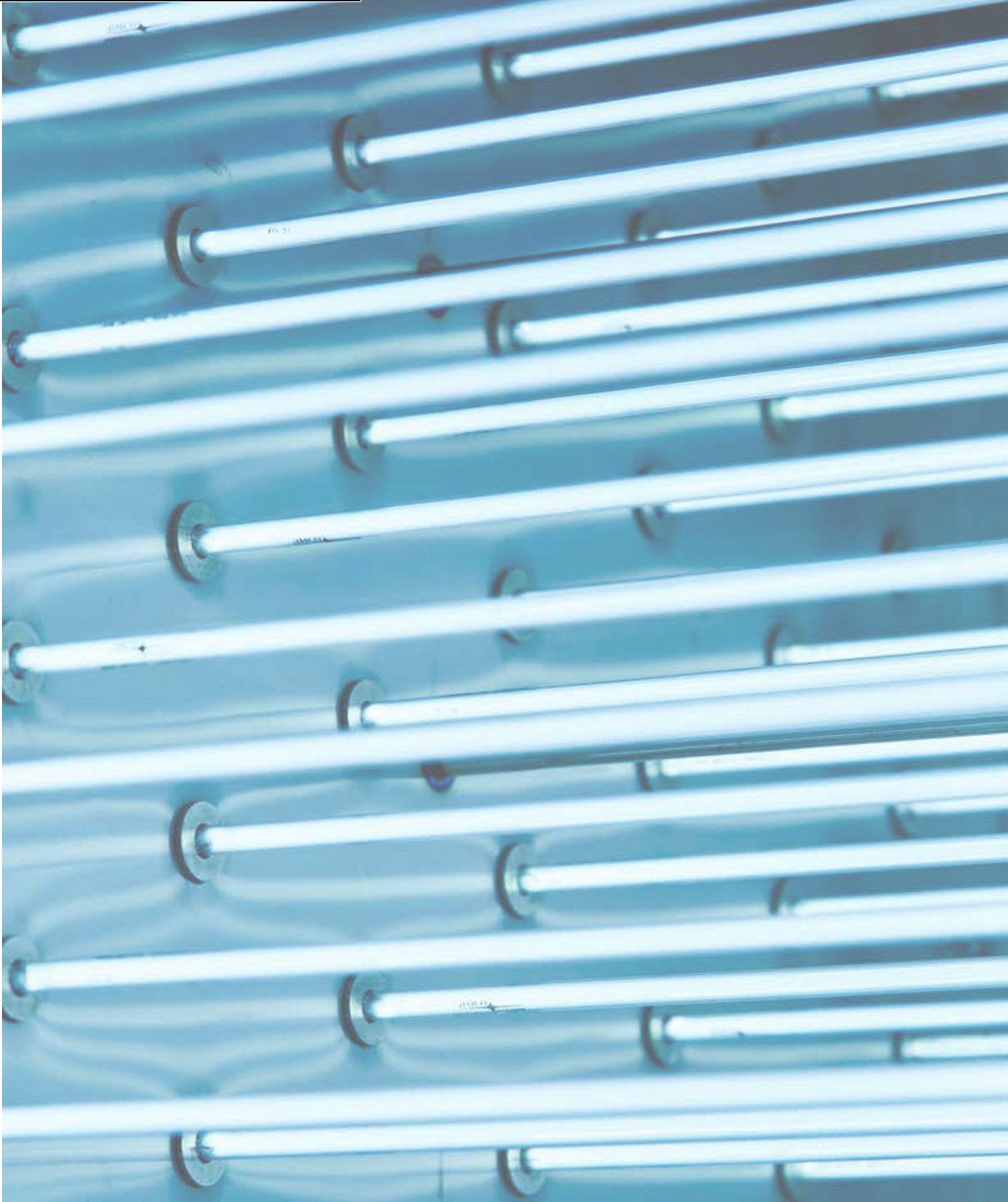

# INNOVATION AND DRIVE

Technology for the future - designed and developed in Denmark

Jimco A/S is the company behind some of the world's most unique air and waste-water purification and sterilisation solutions.

Since designing its very first air-cleaning unit in 1993, Jimco A/S has not looked back. Today, the company supplies its products to a large number of industries and institutions worldwide. Its customer base comprising factories within the food industry, commercial kitchens, waste-water treatment plants, schools and nursing homes. In brief, Jimco A/S undertakes all types of projects – large and small.

Jimco A/S combines common sense with innovative thinking as the basis of the company's unique products. It is no coincidence that Jimco A/S supplies air-treatment units to some of the biggest chains in the world – including McDonald's, Scandic Hotels, McCain, Danish Crown etc.

## COMPLETE DISINFECTION OF SURFACES IN PRODUCTION FACILITIES

### Fighting the spread of bacteria and viruses

With the introduction of the UV-C-based disinfection of surfaces, we now add yet another field of application to our patented UV-C technology, which has been awarded the EU Environmental award and which since 1993 has been used in air cleaning – systems which i.a. are used for removing obnoxious smells, improving the indoor climate as well as reducing the danger of fire and infection.

The fact that it is now possible to disinfect surfaces, which would normally require a manual treatment, involves a large number of advantages for the operating economy, the environment as well as the work environment.



### WHY CHOOSE JIMCO DISINFECTION TECHNOLOGY?

- ✓ Avoid time-consuming manual disinfection of surfaces and equipment
- ✓ The use of UV-C technology has no impact on the environment and is safe for people
- ✓ Disinfection of air ducts, ventilation ducts, cooling pipes and other surfaces
- ✓ The use of UV-C technology has no impact on the environment and is safe for people
- ✓ Avoid an environmentally harmful disinfection process

# PRACTICAL USE

# SURFACE DISINFECTION AND ODOR REMOVAL

Gppe Joevtusz Ć Sfgsjhfsbufe Dpoubjofst Ć Mjnjufo Bsfbt Ć Ifbmui Tfdups

## It can be expensive.

A food production factory can be exposed to bacteria and mould even if a high standard of hygiene is in place. Manual surface disinfection of work surfaces, machinery and freezers etc. can often allow an unusually high number of bacteria to remain.

Unpleasant odors can also cause inconvenience. In these cases, money may be lost through complaints, resulting in bad publicity, and spoilt products.

## It is easy to be at the front edge.

By simple use of the mobile FLO-D® air cleaners, you will quickly and effectively disinfect and remove unpleasant odors from the air in a confined production space.

The daily cleaning of production areas is the most important function, in order to maintain a high standard of hygiene and by using the FLO-D® you will also prevent mould, fungus or any other type of micro-organisms from forming on equipment, walls or ceilings.



## VERY POSITIVE RESULTS – OF TESTS AS WELL AS PRACTICAL USE

Prior to the introduction of our solutions for UV-C & Ozone-based disinfection, we have for some time conducted full-scale tests in various companies in cooperation with DTU (Technical University of Denmark) and The National Institute for Aquatic Resources. The results were impressive.

Furthermore, various tests carried out in cooperation with The South Danish University have shown that concentrations of for instance listeria and salmonella bacteria can be almost completely destroyed by means of our technology and within only two hours.

## SOME FACTS ON OZONE AND ITS USE

1.

Ozone is a potent antimicrobial agent, which can effectively kill viruses, bacteria, fungi and parasites, including those causing food spoilage or human diseases.

2.

The efficiency of ozone depends on the target microorganism and the treatment condition.

3.

Ozone destroys microorganisms by reacting with particular oxidizable cellular components, the end reactions of which result in cell damage and death of microorganisms.

4.

Ozone as opposed to other chemical treatments destroys microorganisms instantly and effectively, without leaving harmful residues in treated food or surfaces, hence is safer and environmentally friendlier than most other antimicrobials.

5.

The production and use of ozone in food processing is safe, provided that its concentration is controlled and monitored. The permissible level of exposure to ozone is 0.1 ppm in workplace and food processing environments for 8 hours.

## FIND OUT HOW MUCH YOU CAN SAVE

It is easy to calculate the amount of savings that your company will be able to gain in terms of manpower, water, heat, electricity and chemicals, simply by shifting to an automatic, environmentally friendly disinfection.

Solutions for UV-C & Ozone-based disinfection can be rented at Jimco A/S.

# AUTOMATIC DISINFECTION OF COLD STORAGE

Ejtjogfdu fggfdujwfmz . xjuipvu nbovbm qspdftht- difnjdbmt ps xbufs

Production manager Morten Tønder from Danfrugt A/S. says: -The results demonstrate that UV-C produced ozone is beneficial to the production environment. In practice, this means that we can keep our exotic fruits fresh for two weeks longer. Danfrugt is one of Denmark's leading fruit growers and one of Jimco's customers, who has installed, tested and purchased Jimco's new technology.



## Mixing apples and pears

In addition to the minimization of mould and yeast growth, the system has other benefits. It also reduces ethylene in the air, normally secreted by apples. This enables the possibility of mixing different fruit types. Normally, apples cannot be stored in the same cold storage rooms as a number of other fruits. However, the concentration of ethylene, which causes e.g. pears to rot faster, is minimized with the FLO-D® technology. Thus, new opportunities are offered for storage of different fruits in the same cold storage rooms. It is an advantage, because we can then close down a few cold storage rooms and gather various fruits together in the same room when the high season is coming to an end, says Morten Tønder.

# HYGIENE ON A LEVEL BETTER THAN TRADITIONAL DISINFECTION

At the fish factory Vega Salmon A/S in Esbjerg, Jimco's system for UV-C & Ozone-based disinfection has been installed in the production. Tests from the factory show that the total bacterial concentration after a UV-C & Ozone-based disinfection is better/lower than after a traditional disinfection.

At the same time, the concentration of fungal spores is reduced. This goes to prove that saving tons of water and chemicals has no hygienic consequences.



# COLD STORAGE

## KILL MOULD, YEAST AND ETHYLENE

No need to use so many resources to effectively clean your cold store. Avoid premature wastage of your precious fruits.

JIMCO A/S has performed tests and analysis, depicting significantly lower concentration of both mould and yeast when using the FLO-D®.

## SAVE MONEY

The shelf life of food has always played an important role. For example, ethylene, mould and yeast shorten the time in which the food stays fresh. In the fruit industry, among other places, mould and yeast growth is a tough opponent affecting product lifespan. FLO-D® (photolysis oxidation disinfection) will help revolutionize the way fruit is stored. The FLO-D® uses UV-C-Technology

to kill the bacteria, mould and yeast in the cold storage, hence optimizing the lifespan of fruits.

### Cleans within a few hours

One FLO-D® unit is capable of cleaning a cold storage room of up to 1,500m<sup>3</sup> within a few hours.

## TREATMENT WITH & WITHOUT UV-C PRODUCED OZONE

With ozone



Grapes

Without ozone



With ozone



Tomatoes

Without ozone



Oranges

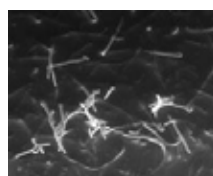

Tomatoes

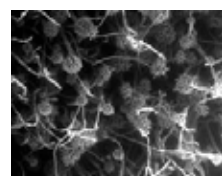

## TECHNICAL DESCRIPTION

## GMP.E®

UV-lamps: 30 pcs. 89 watt

Quartz sleeve: 30 pcs. (in cold storage)

Qpxfs tvqqmz FV; 3x400V + PE 50/60Hz, 16A

Qpxfs tvqqmz VT; 3x480V + PE 50/60Hz, 16A

Dpotvnqujpo; 9 kW

Display: Siemens PLC, Proface color panel

Treatment capacity: Roomsize up to 1,500 m<sup>3</sup>

## Measurements:

Height 2,100mm

Width: 1,200 mm

Depth: 1,200 mm

Weight: 175 Kg



# FLO-D® MINI

NEW

## TECHNICAL DESCRIPTION

### GMP.® MINI - Mark 2

UV-lamps: 8 pcs. 70 watt

Quartz sleeve: 8 pcs. (in cold storage)

Qpxfs tvqqmz FV; 1x230V + PE 50/60Hz, 10A

Qpxfs tvqqmz VT; 1x115V + PE 50/60Hz, 10A

Dpotvnqujpo FV; 640 watt

Dpotvnqujpo VT; 685 watt

Display: Proface PLC, color panel

Sppn.wpmvnf; Disinfection: Up to 314 m<sup>3</sup>

Odor treatment: Up to 1.258 m<sup>3</sup>

### Mesurements:

Height: 1150 mm

Width: 560 mm

Depth: 890 mm

Weight: 59 Kg



# FLO-D<sup>®</sup> FIXED

FLO-D Fixed, allows you to have any size of production area, no area is to big

FLO-D Fixed is a development used for installation where absolute no failure is allowed, and more than one person has the responsibility of the disinfection

FLO-D Fixed also allows you to install the system in a pipe installation. As an example you can use one unit for disinfection of more chillers, by use of dampers.

Contact Jimco for more information on FLO-D Fixed

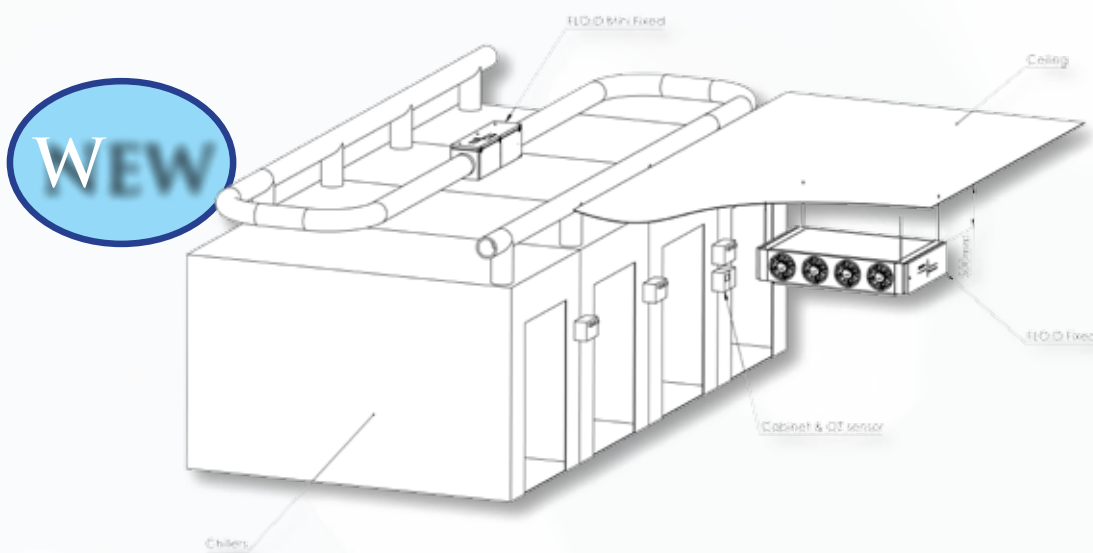

# FLO-D<sup>®</sup> TECHNOLOGY

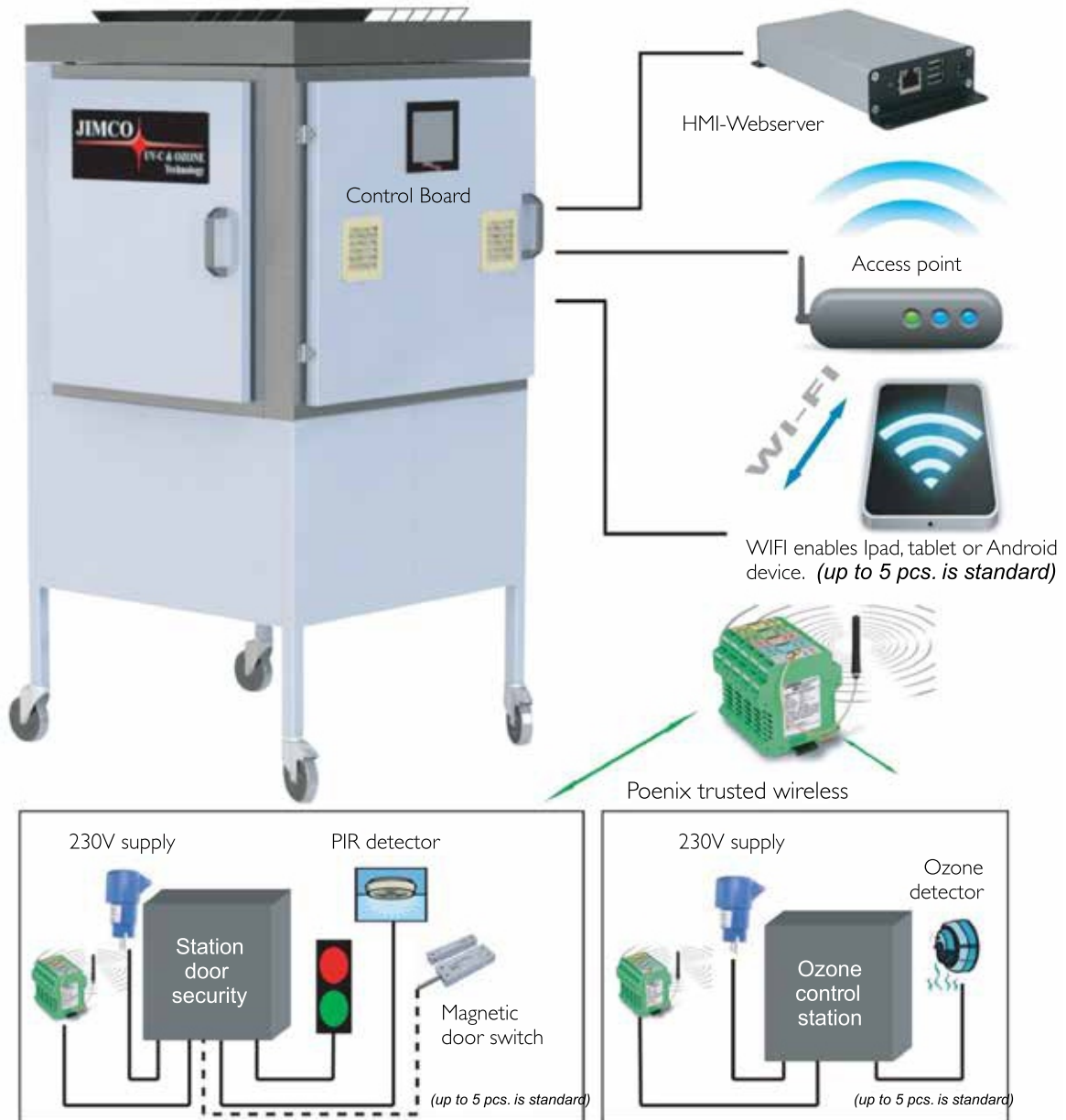

Each entrance is monitored by a PIR sensor or magnetic door switch.

There are warning lamps at each input. Status of ozone levels can be read via FLO-D's website outside the room with a handheld Web browser (tablet, Iphone etc.).

All signals from the doors and ozone sensor handled wirelessly. However, all stations must have a 230V supply.

Single-station and measuring stations come with up to 5 pcs. per installation by default, but it is possible to connect more.

# TEST OF JIMCO FLO-D® DISINFECTION EQUIPMENT BASED ON UV-C/OZONE



## Aim of project

To investigate the bactericidal effect of UV-C produced ozone on chosen bacteria strains that are regarded as relevant contaminants in the food processing industry. Furthermore, it was desirable to determine a setting for the ozone concentration and the time of exposure, in achieving the desired effect.

## Experimental setup

The test was performed in a special designed ozone chamber; where the ozone concentration and the temperature were measured during the experiments. 10 µl of bacteria culture was applied on stainless steel plants and spread to an area of 1 cm<sup>2</sup>. The bacteria culture was diluted in sterile milliQ H<sub>2</sub>O to a concentration of 10<sup>5</sup>-10<sup>7</sup> cells/ml. The steel plates were incubated at room temperature for one hour until the applied culture had dried out. The plants were then placed in the ozone chamber and exposed to various ozone concentrations for time point.

Bacteria survival was measured by washing the applied area on the steel plates with 2x50 µl 0.9 % NaCl, which was obtained and spread on agar plates for CFU determination by overnight incubation at 37 °C. As a reference, the CFU of bacteria applied on stainless steel that were not exposed to ozone, was also performed. The experiments were performed at room temperatures that did not exceed 23 °C during the experiments.

## Conclusion

In these experiments, the largest effect was observed after two hours of exposure at 10 ppm. When the time exposure was reduced to one hour, or the concentration of ozone was lowered to 5 ppm, the reduction of bacteria was distinctively decreased. Furthermore, the effect of ozone was limited by the amount of bacteria applied on the steel plates.

Xifo uif mfwfm pg cbdufsjb fydfefe 216 cbduf-  
ria per cm<sup>2</sup>, the effect of ozone also decreased  
bgufs uxp ipvst pg fyqptvsf bu 21 qqn/

However; with a reduction that is within the accepted range. Also, this amount of bacteria exceed the level of what would be representative of well-cleaned food production facilities, which is the premise for the application of the device.

Exposure time	Ozone concentration	Loaded CFU/cm <sup>2</sup>	Control CFU/cm <sup>2</sup>	Ozone CFU/cm <sup>2</sup>	Reduction	
2 hour	10 ppm	2,40E+03 (2400)	4,00E+00 (4)	0,00E+00 (0)		
		3,30E+03 (3300)	8,00E+00 (8)	0,00E+00 (0)		
		3,00E+03 (3000)	7,00E+00 (7)	0,00E+00 (0)		
			1,60E+01 (16)	0,00E+00 (0)		
		Average	2,90E+03 (2900)	8,75E+00 (8,75)	0,00E+00 (0)	100,00%
2 hour	10 ppm	2,00E+04 (20.000)	3,00E+00 (3)	0,00E+00 (0)		
		2,00E+04 (20.000)	1,40E+01 (14)	0,00E+00 (0)		
		2,00E+04 (20.000)	2,80E+01 (28)	0,00E+00 (0)		
		Average	2,00E+04 (20.000)	1,50E+01 (15)	0,00E+00 (0)	100,00%
		2,80E+04 (28.000)	3,00E+01 (30)	0,00E+00 (0)		
2 hour	10 ppm	2,20E+04 (22.000)	1,13E+02 (113)	0,00E+00 (0)		
		2,80E+04 (28.000)	3,40E+01 (34)	0,00E+00 (0)		
		Average	2,80E+04 (28.000)	5,90E+01 (59)	0,00E+00 (0)	100,00%
		3,80E+05 (380.000)	3,98E+02 (398)	0,00E+00 (0)		
		2,20E+05 (220.000)	2,85E+02 (285)	1,00E+00 (1)		
2 hour	10 ppm	2,80E+05 (280.000)	2,97E+02 (297)	0,00E+00 (0)		
		Average	2,80E+05 (280.000)	3,27E+02 (327)	3,33E-01 (0,33)	99,90%

# From $O^2$ to $O^3$ to $O^2$

Article from MEAT & CO  
Holland February 2017

Safe processing  
with the ozone solution from Baaijens



JIMCO sells various air cleaning systems with UV-C and ozone technology and is thus specialized in the elimination of microorganisms and scents. JIMCO supplied and installed three FLO-D units at Levenstond Seafood.

The machine works as follows: by means of UVC light, oxygen is converted into ozone, through a process which, in this case, is reversible. That means neutral air is emitted again.

This technology is applicable to the complete food industry.

Levenstond Seafood was established in 2007 when founder Axel Verberkmoes had the intention to process salmon for Delhaize with about 10 employees. In 2017, the Belgian company processes 5,000 tonnes of fish per year into 30,000 consumer packages per day, in two production departments, four cash&carries and two sourcing platforms, one of which is in Vietnam. The family company serves almost the whole retail sector in Belgium, including Delhaize, Colruyt, Spar, Carrefour, Lidl and Aldi.

Besides Levenstond Seafood, the group of family companies consists of Van dermaesen which was taken over in 2012 and LSF Services, which was created out of necessity.

Axel: "Nowadays, as a food company, you can no longer do without IT. It has become a huge expense for companies. The work is often outsourced as the companies themselves do not have enough know-how. It is expensive and the result is often insufficient. We are talking about links, control, ERP software and so on. As a food company, you have a huge amount of obligations. You must be able to pass on information to your customers. Retailers are demanding because the market requires them to be. The customer wants to know with what boat you are fishing, whether you use hooks and when the fish is caught from the sea.

What has been done to the products, what temperature they have been processed at, if you have to be able to answer all those questions, apart from quality control and margin controls, you need enter the IT domain quickly. To this end, we have established LSF Services, which focuses on domotics for the food plant."

Axel: "When you process fish, every day again you introduce listeria to the production process. That is inherent to the product. At the start, we have set up a system to disinfect with chemicals. First cleaning, then disinfecting with a disinfectant product, such as chlorine. That works, but that only cleans the surface and machines require more. They have holes and gaps.

After several years, it has emerged from testing that it is becoming more and more difficult to obtain good results. That is why we actively went in search for a better solution. We got into contact with the people from JIMCO, who presented us with a device based on ozone, which ensures that, in fact, the whole area, each hole, and even the air is sterilized. Now we have three of these devices. A fantastic investment!"

When working with ozone, the air in the room is changed into  $O^3$ , treats the room and goes back to  $O^2$  after the treatment. Axel: "You must ensure that at that moment, nobody can enter; the cleaning is timed and measured and also that you can report afterward. So, the device by itself, which is a standalone device, is a part of the solution. Because we have LSF Services, we started talking to Jimmy Larsen to turn the standalone solution into a complete concept, which makes the system user-friendly.

The devices from JIMCO are amazing. We gain a lot of time during the cleaning process, use half of the water; do not use chemicals and thus work more environmentally friendly and cost saving. In addition, the results are available online and they are always very good. Above 7 ppm we know we have cleaned well, but we are always above it. You also note from the results that the cleaning gets better and faster. While initially, it took seven to eight hours to achieve a good result, now it is done in two to three hours." Axel adds: "It is important to note that the process of converting to ozone, to  $O^3$ , is reversible. After a few hours, we emit neutral air again."

"The Belgian FAVV and the Dutch NVWA are often approached with suspicion", Axel believes.

"But when you approach them proactively and talk to them, the contact is often fine. That is what we did when we started cleaning with the Jimco FLO-D. We also brought our test results straight away. The FAVV is very positive about our company and the results. Which are simply wonderful. This investment pays back within one year!"

# AWARDS AND PATENTS

**THE EU ENVIRONMENTAL AWARD 1999 – 2000**

**JIMCO A/S**

An environmental award in the category

**CLEANER TECHNOLOGY**

The purpose of this award is to encourage the development and use of technology, which considerably reduces the unwanted influence of the industry on the environment. It can be production technology or processes, which improve the utilization of resources, integrate recycling in the production, improve the lifecycle sequence of the product or the technology or in other ways contribute to the development of viable production. By the award of projects in this category importance will be attached to the innovative aspect and documented better resource economy compared to traditional production forms. The technology should be in use or have documented results from full-scale tests. Simple filter solutions cannot be considered.

**Motivation:**

**JIMCO A/S** is given an environmental award in the category cleaner technology for the development of Photo-Lytic-Oxidation-Systems for the reduction of odours, grease and oil using ultra violet light. The UV-light form ozone, which oxidises the odour substances/grease molecules in the air and thereby reduce obnoxious smells effectively. At the same time you will be using JIMCO's FLO-system avoid grease contamination of ductwork and fans and thereby considerably reduce the risk of fire as well as the problems of disposal of filters. The odour substances are transformed into CO<sub>2</sub>, water and polymerised waxes. FLO-units are made in various sizes and are thus suitable for the use in restaurants as well as the industry etc. With the air-cleaning unit you will also have a compact installation, avoid the use of carbon filters or catalysts, no residues, competitive initial cost and low operational and maintenance costs. It is the opinion of the judging committee that JIMCO with the development of this system has found a simple and effective solution to a prevalent problem.

*Jim Niemann*  
Jim Niemann  
The Danish Engineers Society  
Chairman of the judging committee

*Kristian Svendsen*  
Kristian Svendsen  
The Danish Engineers Society  
Secretary of the judging committee

The Environmental Award Competition has been arranged in cooperation with the EU-Commission and UNEP. The purpose of the Award Competition is to encourage and promote commendable initiatives in the environmental field.

The judging committee of the award have been composed of representatives appointed by The Danish Ministry for Environment and Energy, The Danish Trade Ministry, Danish Industry, The Trade Counsel of the Danish Labour Movement, The Danish Nature Conservancy Association and The Danish Engineers Society, who have handled the chairmanship and the secretariat and been in charge of the completion of the prize-giving.

**THE DANISH ENGINEERS SOCIETY** 



The EU Environmental Award for Cleaner Technology.



Worldwide patents of Jimco Technology.

**JIMCO®**

**UV-C & OZONE  
Technology**

**JIMCOINDIA**

**UV-C & OZONE  
Technology**

UV-C AND OZONE SOLUTIONS FOR THE FUTURE  
EUROPE · SOUTH AMERICA · USA · ASIA · MIDDLE EAST

**JIMCO TECHNOLOGY REFERENCES**



Address: 3/1, Krishnamma Naicker Lay out, Varatharaja Puram, Coimbatore - 641 015, India

Ph: +91 90434 72333, +91 98434 72333

E-mail: Jimcoindia@gmail.com

[www.jimcoindia.in](http://www.jimcoindia.in)